

# Intermediate ring with connection, PN 16

# 8580

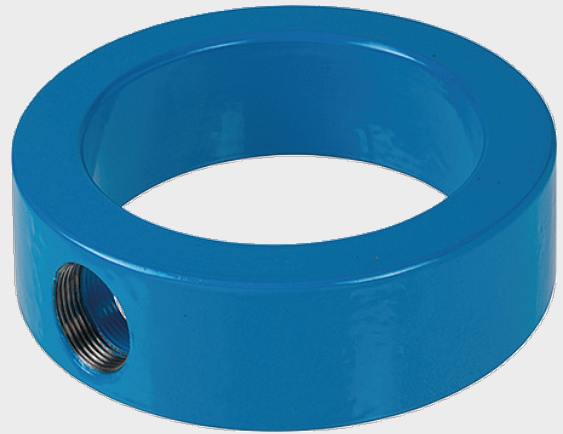
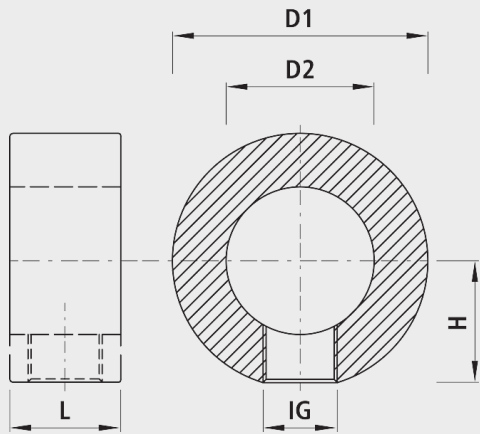

### Installation and assembly

- The intermediate ring is clamped between two flanges with two seals.
- Flanges measured according to EN 1092-2(DIN 28605)
- Pressure levels standard

### Material

- Housing  
- EWS coating according to GSK, RAL-GZ 662, coating thickness min. 250 µm

### Caution

- Special construction lengths with outlets in various sizes as well as special shapes according to sketches are available on request.

	DN	PN (bar)	D1 (mm)	D2 (mm)	L (mm)	H (mm)	IG	weight (kg)	NPK No. 411	NPK No. 412
8580050025	50	16	105	55	60	45	3/4"	2.800	877536	271518
8580065025	65	16	125	70	60	60	3/4"	3.800	877537	271519
8580080040	80	16	140	89	60	65	1 1/4"	3.900	877538	271521
8580100040	100	16	160	114	60	75	1 1/4"	4.300	877539	271522
8580125040	125	16	190	125	60	90	1 1/4"	6.900	877541	271523
8580125063	125	16	190	125	85	90	2"	9.900		271523
8580150040	150	16	218	158	60	105	1 1/4"	8.100	877542	271524
8580150063	150	16	218	158	85	105	2"	9.500		271524
8580200040	200	16	268	216	60	130	1 1/4"	8.400	877543	271525
8580200063	200	16	268	216	85	130	2"	10.200		871525