

Bend HAWLE-GRIP 11°, PN 16

7343

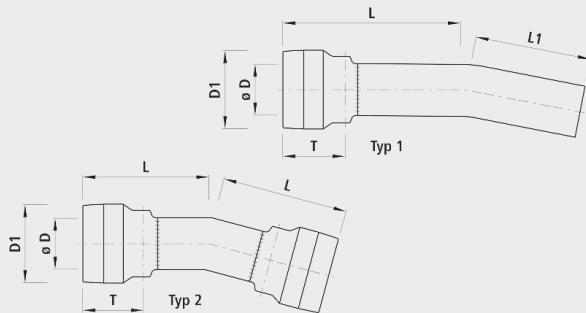

Application

- The HAWLE-GRIP connection was developed for the water supply to connect PE pipes SDR 11 or SDR 17 with a simple push-fit connection.
- The HAWLE-GRIP connection can also be used in the event of water running behind or in situations where the welding technique fails.
- The HAWLE-GRIP connection can be installed in a space-saving and de-energised manner.
- The HAWLE-GRIP connection is always used where the water pipe has to be put back into operation quickly and there is no time for the welding technique with cooling tim.
- The shear-resistant plug-in connection saves a lot of time and therefore money compared to welding technology.

Product information

- DN 250, DN 315, DN 355, DN 400 and DN 450 available on request

Characteristics

- Type 1: with double sleeve
- Type 2: with spigot-end and a sleeve
- Patented train protection system
- Flange connection compound - according to EN 1092-2
- Operating temperature - max. 40 °C
- Pressure PN 16
- SGVW certified

Material

- Socket body
 - Plastic PE 100 RC
- Shear protection elements
 - High-strength plastic
 - Spring-mounted individual segmentsC
- Lip seal
 - EPDM/System 3S

	ø D	Type	PN (bar)	L (mm)	L1 (mm)	T (mm)	D1 (mm)	weight (kg)	NPK No. 411	NPK No. 412
7343090001	90	1	16	280	220	140	152	1.900	433237	451236
7343110001	110	1	16	315	230	170	175	3.200	433238	451237
7343125001	125	1	16	320	260	172	190	4.000	433239	451238
7343160001	160	1	16	350	300	183	234	8.000	433242	451242
7343180001	180	1	16	400	330	211	260	9.700	433243	451243
7343200001	200	1	16	450	420	231	285	13.000	433244	451244
7343225001	225	1	16	470	450	236	315	16.500	433245	451245
7343090000	90	2	16	280		140	152	3.000	433437	451436
7343110000	110	2	16	315		170	175	4.600	433438	451437
7343125000	125	2	16	320		172	190	5.800	433439	451438
7343160000	160	2	16	350		183	234	9.700	433442	451442
7343180000	180	2	16	400		211	260	12.600	433443	451443
7343200000	200	2	16	450		231	285	16.700	443444	451444
7343225000	225	2	16	470		236	315	21.000	433445	451445