

PE weld-in Hawlinger ZAK[®], PN 16

2280

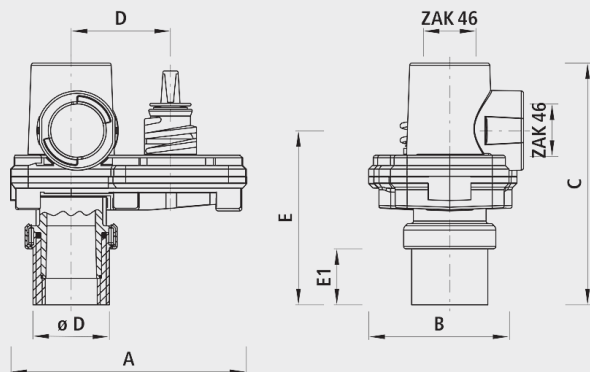

Application

- The PE d 63 mm weld-on end can be welded with customary Heizwendel clamps.

Characteristics

- Vertical and horizontal outlet ZAK[®] 46
- Operating temperature
 - max. 40 °C
- Pressure PN 16
- Integrierter Korrosionsschutz
 - Metallische, unbeschichtete Gewindeoberflächen in Armaturen führen zu Korrosion und Inkrustation. Die Folge sind reduzierte Durchflussleistungen und hohe Sanierungskosten.

Material

- Gehäuse
 - Späroguss EN-GJS-400 (GGG 40)
 - EWS-Beschichtung nach GSK, RAL-GZ 662, Schichtdicke min. 250 µm

		ø D	ZAK [®]	PN (bar)	A (mm)	B (mm)	C (mm)	D (mm)	E (mm)	E1	Drill-ø max. (mm)	weight (kg)	NPK No. 411
2280046063		63	46	16	195	125	210	82	155	56	35	6.300	816455
2280146063	x	63	46	16	195	125	200	81	145	50	35	6.300	

x = With integrated drain function. After the fitting is closed, it empties automatically.