

## Connector HAWLE-GRIP can be looped , PN 16

7222

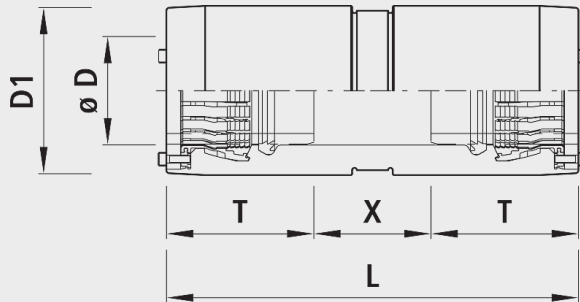

### Application

- Can be looped for the repair of plastic pipes
- The shearing protection is activated by tightening the tension bolts on the stop.
- The HAWLE-GRIP connection was developed for the water supply to connect PE pipes SDR 11 or SDR 17 with a simple push-fit connection.
- The HAWLE-GRIP connection can also be used in the event of water running behind or in situations where the welding technique fails.
- The HAWLE-GRIP connection can be installed in a space-saving and de-energised manner.
- The HAWLE-GRIP connection is always used where the water pipe has to be put back into operation quickly and there is no time for the welding technique with cooling tim.
- The shear-resistant plug-in connection saves a lot of time and therefore money compared to welding technology.

### Characteristics

- Patented train protection system
- Flange connection compound  
- according to EN 1092-2
- Operating temperature  
- max. 40 °C
- Pressure PN 16
- SGVW certified

### Material

- Socket body  
- Plastic PE 100 RC
- Shear protection elements  
- High-strength plastic  
- Spring-mounted individual segmentsC
- Lip seal  
- EPDM/System 3S

	<b>ø D (mm)</b>	<b>PN (bar)</b>	<b>L (mm)</b>	<b>T (mm)</b>	<b>X</b>	<b>D1 (mm)</b>	<b>weight (kg)</b>	<b>NPK No. 411</b>	<b>NPK No. 412</b>
7222090000	90	16	422	150	117	152	4.000	442217	453216
7222110000	110	16	425	152	117	175	4.900	442218	453217
7222125000	125	16	435	156	118	190	6.300	442219	453218
7222160000	160	16	452	164	120	234	9.400	442222	453222
7222180000	180	16	538	194	145	260	13.100	442223	453223
7222200000	200	16	546	198	145	285	18.100	442224	453224
7222225000	225	16	556	203	145	315	23.100	442225	453225