

# Sewage slider incl. loose flanges, tension strength, PN 10

4013

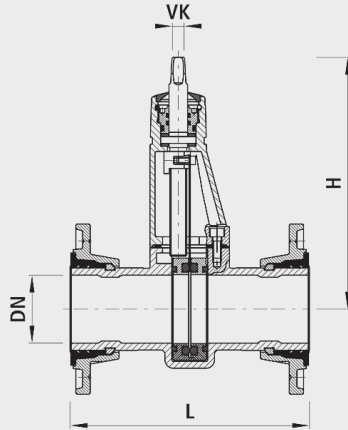

## Characteristics

- Suitable for underground installation
- Spindle outside the flow medium
- Incl. flange seals for loose flanges
- Loose flange can be freely rotated, resistant to tensile forces with the stop ring
- Absperrfunktion durch Steckscheibe aus nichtrostendem Stahl
- Patentierter Absperrmechanismus
- Spindel ausserhalb des Mediums liegend; geschützt im Oberteil
- Assembly and disassembly possible without installation/removal piece
- Operating temperature  
- max. 40 °C
- Flange connection compound  
- according to DIN EN 1092-2
- Druckstufe PN 10

## Material

- Housing  
- Spheroidal graphite cast iron EN-GJS-400 (GGG 40)  
- EWS coating according to GSK, RAL-GZ 662, coating thickness min. 250 µm
- Oberteil  
- Sphäroguss EN-GJS-400 (GGG 40)  
- EWS-Beschichtung nach GSK, RAL-GZ 662, Schichtdicke min. 250 µm  
- Versenkte, versiegelte Schrauben
- Absperrerelement  
- Hartgewalzter Stahl (INOX);  
Zugfestigkeit mind. 1200 N/m<sup>2</sup>
- Spindelabdichtung  
- O-Ring-Träger: Messing (ab DN 80 auswechselbar)
- Dichtungen  
- Gummi

## Caution

- Reduce screw length to make it 5 mm shorter than a standard flange connection. Only use one washer per screw.

|            | DN  | PN (bar) | H (mm) | L (mm) | Handwheel-DN | VK   | Drill-ø max. (mm) | weight (kg) |
|------------|-----|----------|--------|--------|--------------|------|-------------------|-------------|
| 4013050000 | 50  | 10       | 205    | 250    | 40           | 12.3 | 48                | 8.600       |
| 4013080001 | 80  | 10       | 295    | 180    | 50           | 14.8 | 76                | 14.000      |
| 4013100001 | 100 | 10       | 320    | 190    | 50           | 14.8 | 96                | 17.000      |
| 4013125001 | 125 | 10       | 424    | 200    | 80           | 17.3 | 121               | 27.000      |
| 4013150001 | 150 | 10       | 410    | 210    | 80           | 17.3 | 145               | 32.000      |
| 4013200001 | 200 | 10       | 530    | 230    | 125          | 19.3 | 172               | 46.000      |
| 4013250001 | 250 | 10       | 832    | 250    | 250          | 27.3 | 247               | 150.000     |
| 4013300001 | 300 | 10       | 807    | 270    | 250          | 27.3 | 297               | 178.000     |

