

Non-return flap, type AVK, PN 16

9966

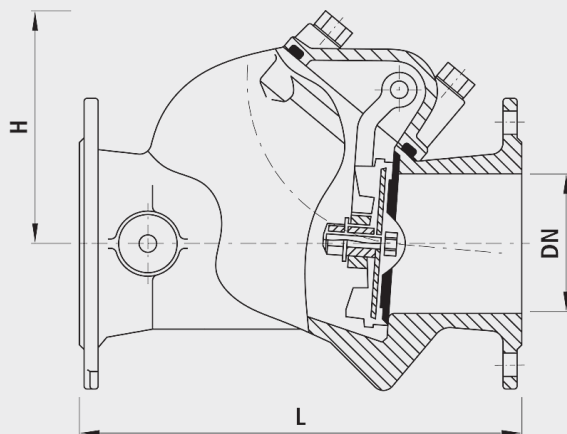

Application

- For water up to max. 40 °C

Characteristics

- Flange connection compound
 - according to DIN EN 1092-2
 - DN 40 to DN 150: PN 10 / 16
 - DN 200 to DN 00: PN 10 or 16, specify when ordering
 - DN 65: Flange with 4 hole

Material

- Housing, hood and articulation: Ductile-cast GGG50 acc. to DIN 1693
- EWS epoxy coating according to GSK, RAL-GZ 662, internally and externally acc. to DIN 30677
- Shaft: INOX 1.4057
- Valve: EPDM, with steel insert

	DN	PN (bar)	L (mm)	H (mm)	weight (kg)	NPK No. 411	BIM / CAD
9966050000	50	16	200	110	15.800	832116	
9966065000	65	16	240	140	18.800	832117	
9966080000	80	16	260	140	19.800	832118	
9966100000	100	16	300	150	23.900	832119	
9966125000	125	16	350	195	41.600	832141	
9966150000	150	16	400	195	56.600	832142	
9966200000	200	10	500	230	88.700	832123	
9966200016	200	16	500	230	88.700	832143	
9966250000	250	10	600	345	196.000	832124	
9966250016	250	16	600	345	196.000	832144	
9966300000	300	10	700	385	244.000	832125	
9966300016	300	16	700	385	244.000	832145	