

Combi-T BLS[®], PN 16

4330

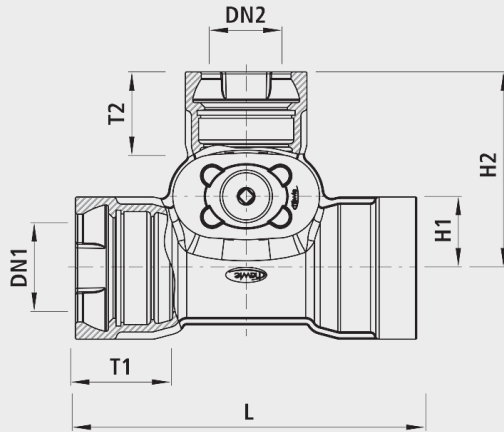

Application

- The BLS[®] socket can be used for pipes with welding beads that are secured against shearing by means of bolts. If a TYTON-SIT seal is used, for example, the fitting can also be used for all push-in socket pipes. The fittings are designed using the proven E3 gate valve technology. All BLS[®] valves and fittings are fitted with TYTON seals for water as standard.

Characteristics

- Operating temperature - max. 40 °C
- Pressure PN 16

Thrust protection

- Shearing protection bolt or clamping ring for pipe end without weld bead
- Shearing protections are not included in the scope of supply.

Material

- Housing
 - Spheroidal graphite cast iron EN-GJS-400 (GGG 40)
 - EWS coating according to GSK, RAL-GZ 662, coating thickness min. 250 µm
- Push-in sockets
 - according to DIN 28603
- Seals
 - EPDM
 - KTW and W 270 approval

	DN1 (mm)	DN2 (mm)	PN (bar)	L (mm)	H (mm)	H1 (mm)	H2 (mm)	T1 (mm)	T2 (mm)	weight (kg)	NPK No. 411	NPK No. 412	BIM / CAD
4330100100	100	100	16	480	343	90	270	135	135	38.200	823312	822112	
4330125100	125	100	16	500	343	105	285	145	135	44.200	823363	822143	
4330125125	125	125	16	525	421	115	320	145	145	59.400	823313	822113	
4330150100	150	100	16	520	343	115	295	150	135	48.600	823364	822144	
4330150125	150	125	16	560	421	120	327	150	145	69.000	823374	822154	
4330150150	150	150	16	560	433	120	331	150	150	72.200	823314	822114	
4330200100	200	100	16	540	343	140	320	160	135	63.000	823365	822145	
4330200125	200	125	16	580	421	147	354	160	145	83.000	823375	822155	
4330200150	200	150	16	580	433	147	358	160	150	87.000	823385	822165	

Height H: Pipe axis up to the spindle end