

Combi-T BLS[®], exit universal PE, PN 16

4321

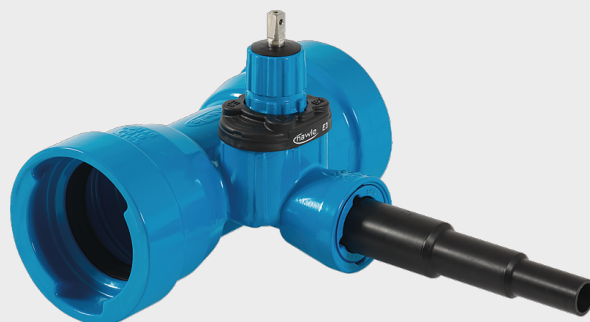
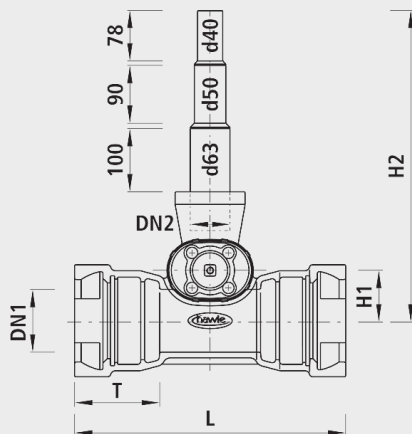

Application

- The BLS[®] socket can be used for pipes with welding beads that are secured against shearing by means of bolts. If a TYTON-SIT seal is used, for example, the fitting can also be used for all push-in socket pipes. The fittings are designed using the proven E3 gate valve technology. All BLS[®] valves and fittings are fitted with TYTON seals for water as standard.
- The surface must be roughened for plug-in or clamp connections.

Thrust protection

- Shearing protection bolt or clamping ring for pipe end without weld bead
- Shearing protections are not included in the scope of supply.

Characteristics





- Operating temperature - max. 40 °C
- Pressure PN 16

Material

- Housing
 - Spheroidal graphite cast iron EN-GJS-400 (GGG 40)
 - EWS coating according to GSK, RAL-GZ 662, coating thickness min. 250 µm
- Push-in sockets
 - according to DIN 28603
- Seals
 - EPDM
 - KTW and W 270 approval

Outlet

- PE-weld-on end, d 63-50-40, PE100-SDR11
- PE weld-on end, factory fitted
- Diameters d 63, d 50 and d 40 suitable for welded socket (shortening at the marking)
- Suitable for Hawle-plug fittings
- DN 250 + DN 300 branch with DN 80 flanged outlet made from 4852

	DN1 (mm)	DN2 (mm)	PN (bar)	L (mm)	H (mm)	H1 (mm)	H2 (mm)	T (mm)	weight (kg)	NPK No. 411	NPK No. 412	BIM / CAD
4321100000	100	50	16	430	234	80	495	135	27.900	824112	822212	
4321125000	125	50	16	440	234	100	515	143	33.800	824113	822213	
4321150000	150	50	16	450	234	110	525	150	39.800	824114	822214	
4321200000	200	50	16	480	234	140	555	160	55.200	824115	822215	
4321250000	250	50	16	510	324	365	765	165	77.000		822216	
4321300000	300	50	16	520	234	395	795	170	91.600		822217	

Height H: Pipe axis up to the spindle end